

Locking Gas Springs

DICTATOR high-performance push type gas springs with additional **locking** raise objects, hold them in any position desired, and then release them again.

The locking push type gas springs are available in two types of locking. With **cushioned locking** the piston rod gives a little in the locked position so the object can recoil. These are easier to manufacture technically and are therefore the more economic variety. If the object needs to remain in a fixed position e.g. hospital beds that tilt, then gas springs with **rigid locking** must be used.

The locking is **released by a pin at the front of the piston rod**. Releasing devices can be found on pages 06.043.00 and 06.044.00.

Other than the hospital bed shown in the drawing, further **examples** of where **locking push type gas springs** are used include aeroplane seats and drawing boards etc.

DICTATOR locking push type gas springs can also be supplied with numerous additional options such as a valve, biological oil, protective tube and oil chamber.

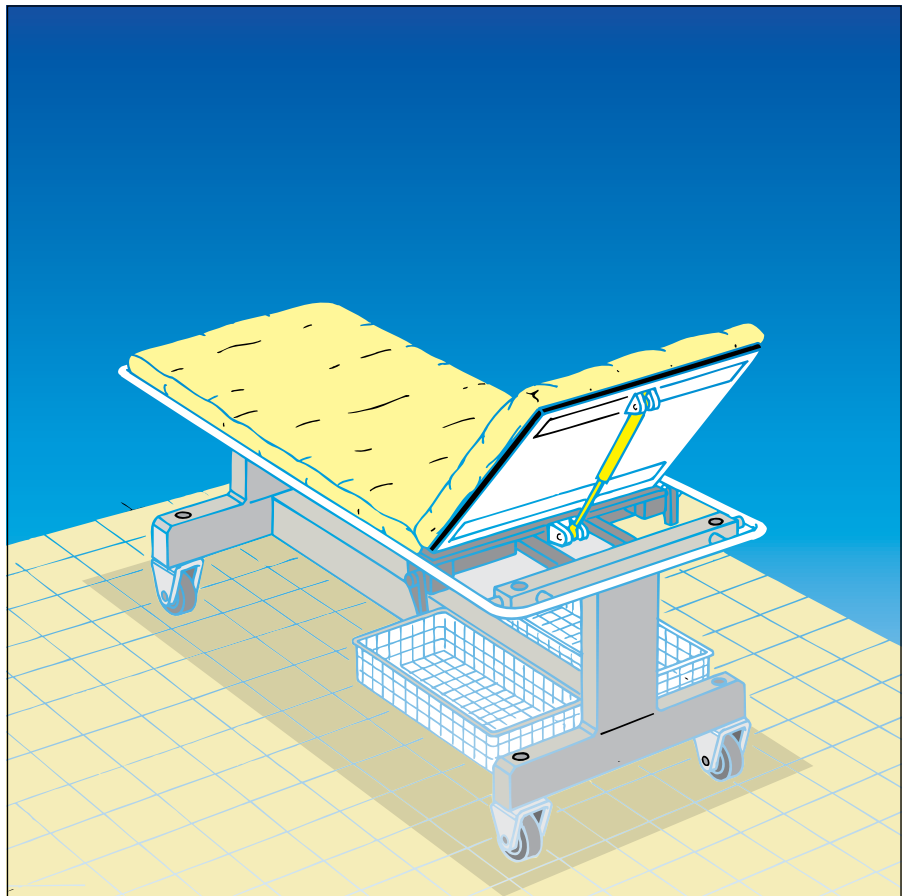

Technical Data

Piston rod diameter	10 mm
Cylinder diameter	23, 28 mm
Force	150 N - 1200 N
Stroke length	20 mm - 500 mm
Locking force in pushing direction	approx. 5 to 6 times the force (50 times on request)
Locking force in pulling direction	0 - approx. 5 times the pushing force
Release distance of pin	1 - 4 mm, depending on design and release pin
Release force	approx. 18 % of gas spring rated force

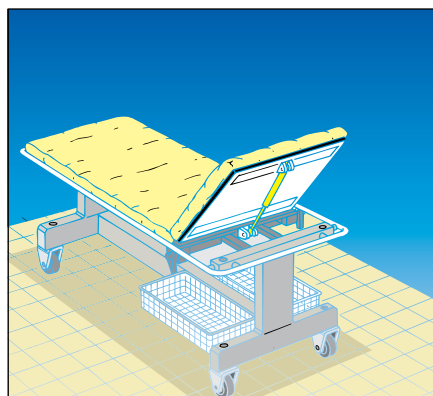

Summary of Locking Gas Springs

DICTATOR industrial push type gas springs are manufactured according to your individual requirements. The table below gives you a short summary of the range of push type locking gas springs available.

You should always choose the range with the larger cylinder diameter if you require the smallest possible progressivity (see page 06.009.00).

Information concerning possible additional options can be found at the bottom of this page. Detailed data concerning locking gas springs can be found on the following pages, which will help you choose the necessary gas spring. Alternatively you can ask our advice.

Technical Data

Locking	Cushioned		Rigid	
	10	10	10	10
∅ Piston rod	10	10	10	10
∅ Cylinder	23	28	23	28
Min. stroke S (mm)	20		20	
Max. stroke S (mm)	500		500	
Damping	0, 3		0, 3	
Min. force	150 N		150 N	
Max. force	1200 N		1200 N	
Comp. L (GZ-GZ) *	ext. L - S		ext. L - S	
Ext. L (GZ-GZ) *	2 x S + 90		2.5 x S + 90	
Piston rod end fittings	GZ M10x1		GZ M10x1	
Cylinder end fittings	GZ, A, G WG, KGA, GK		GZ, A, G WG, KGA, GK	
Oil chamber (4)	L + 15		-	
Valve (5)	option		option	
Protective tube (6) *	L + 5		L + 5	
* Stroke (S) or lengths (L) + additional lengths in mm [Example: StB 10-23 range; stroke 50; ext. L = 2.5 x 50 + 90 = 215 mm]				

Additional Fittings

The piston rod of cushioned locking gas springs should ideally also point downwards in a vertical position. If this is not possible, please order an oil chamber with your gas spring. The oil chamber ensures the seal is always surrounded by oil and therefore cannot become porous. However, this feature is only necessary for cushioned locking gas springs. The **oil chamber** has **code no. 4** (The total length increases by 15 mm/0.59 in. Please also see page 06.010.00).

If you are not entirely sure which pressure you require, it is best to order a valve with your gas spring (or begin with a valve if you are ordering a large number of gas springs). By using a valve pressure can be released on site, until the required force is reached. A valve can therefore save you time and money. Should you release too much pressure, we can refill the gas spring for you. The **valve** has **code no. 5** (please also see page 06.010.00 und 06.011.00).

If your gas spring is going to be used in a dirty and dusty environment, or if there is danger of mechanical damage, please order a protective tube with your gas spring. The protective tube slides over the cylinder and piston rod and prevents damages of the rod. The gas spring can also be supplied with 2 protective tubes on request. The **protective tube** has **code no. 6**. The total length increases by 5 mm per protective tube. (Please also see page 06.011.00).

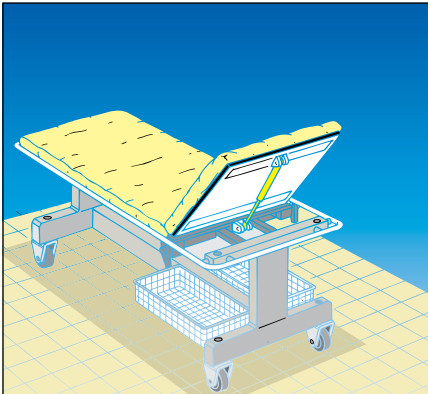

FB 10-23 and FB 10-28 Cushioned Locking Gas Springs

Cushioned locking gas springs are the more economic type of locking gas springs. You can always use them if the positioning has not to be exact and e.g. the flap may recoil a bit in the locked position. They should also be installed in applications where after locking the gas spring exists the possibility that someone pulls or pushes it.

There are several different **release devices** for the threaded ends with release pin. You will find them on page 06.043.00.

End Fittings

On piston rod

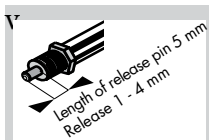

Threaded end **GZ**
M10x1

See page
06.043.00
for release devices

* Eyelet **A**
10-28 series: **16 mm**

On cylinder

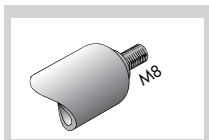

Threaded end **GZ**

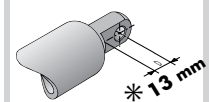

Eyelet **A** 10-23 series

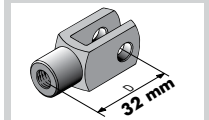

Fork **G**

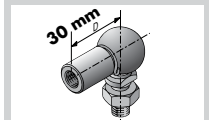

Ball and socket joint **WG**

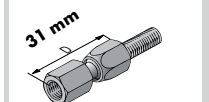

Inline ball and socket joint **KGA**

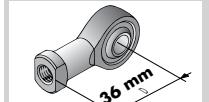

Rose bearing **GK**

Exact dimensioned drawings for the above end fittings can be found on pages 06.061.00 - 06.064.00.

Types of damping for cushioned locking gas springs

0 = without damping

3 = damping on both extending and compression strokes

Determining Your Cushioned Locking Gas Spring

With help of the following table you can easily find the correct gas spring if you already know the necessary stroke and end fittings.

If you require a gas spring not only with threaded ends, but also, for example an eyelet on the cylinder, then simply add measurement D given in the drawings of the end fittings to the extended length to achieve the total length.

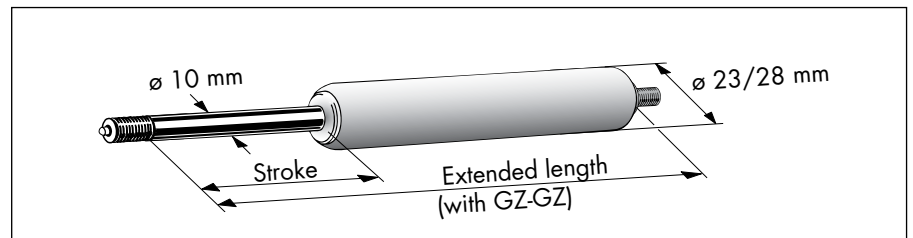

	Type FB	See page
1. Piston rod diameter:	<input type="text" value="10 mm"/>	06.082.00
2. Cylinder diameter (23 or 28 mm):	<input type="text"/>	06.082.00
3. Stroke (20 - 500 mm):	<input type="text"/>	06.082.00
4. Type of damping:	<input type="text"/>	06.005.00 06.083.00
(choice between damping types 0 and 3)		
5. Force (150 - 1200 N):	<input type="text"/>	06.083.00
6. Compressed length (= extended length - stroke):	<input type="text"/>	06.084.00
7. Extended length (total length):	<input type="text"/>	06.084.00
(min. 2 x stroke + 90 mm + measurement D of end fittings + measurements of additional options)		
8. Piston rod end fitting (M10x1 threaded ends):	<input type="text" value="GZ"/>	06.061.00
9. Cylinder end fitting (see drawing for symbol):	<input type="text"/>	06.061.00
10. Additional options:	<input type="checkbox"/> Oil chamber (4) (+ 15 mm) <input type="checkbox"/> Valve (5) <input type="checkbox"/> Protective tube (6) (+ 5 mm)	06.010.00 06.010.00 06.011.00

Additional details: e.g. shorter release pin

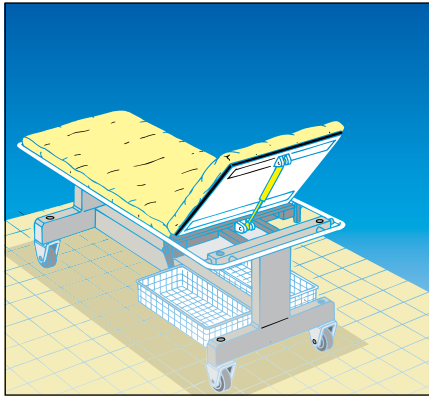

StB 10-23 and StB 10-28 Rigid Locking Gas Springs

Rigid locking gas springs are the more **elaborate design** of locking gas springs to manufacture. The piston rod does not move once in the locked position. The object is fixed in the exact position required and cannot rebound when a load is added e.g hospital beds cannot tilt any further when locked. As a **special design** the 10-28 rigid locking gas springs can also be supplied with up to **50 times the locking force in the force direction** (max. 7500 N). This model is recommended e.g. for hospital beds.

There are several different **release devices** for the threaded ends with release pin. They can be found on the following page.

End Fittings

On piston rod On cylinder

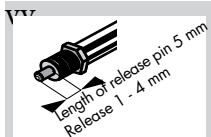

Threaded end **GZ**
M10x1

See page
06.043.00
for release devices

* Eyelet **A**
10-28 series: **16 mm**

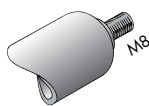

Threaded end **GZ**

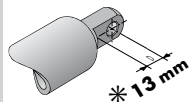

Eyelet **A** 10-23 series

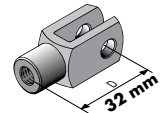

Fork **G**

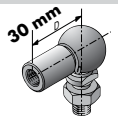

Ball and socket joint **WG**

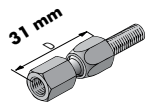

Inline ball and socket joint **KGA**

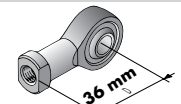

Rose bearing **GK**

Exact dimensioned drawings for the above end fittings can be found on pages 06.061.00 - 06.064.00.

Types of damping for rigid locking gas springs

0 = without damping

3 = damping on both extending and compression strokes

Determining Your Rigid Locking Gas Spring

With help of the following table you can easily find the correct gas spring if you already know the necessary stroke and end fittings.

If you require a gas spring not only with threaded ends, but also, for example an eyelet on the cylinder, then simply add measurement D given in the drawings of the end fittings to the extended length to achieve the total length.

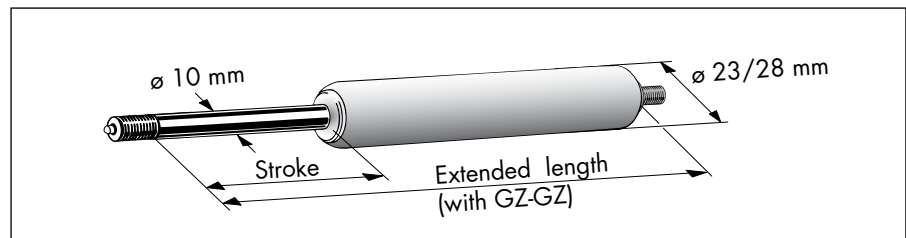

	Type StB	See page
1. Piston rod diameter:	<input type="text" value="10 mm"/>	06.082.00
2. Cylinder diameter (23 or 28 mm):	<input type="text"/>	06.082.00
3. Stroke (20 - 500 mm):	<input type="text"/>	06.082.00
4. Type of damping:	<input type="text"/>	06.005.00 06.083.00
(choice between damping types 0 and 3)		
5. Force (150 - 1200 N):	<input type="text"/>	06.083.00
6. Compressed length (= length extended - stroke):	<input type="text"/>	06.084.00
7. Extended length (total length):	<input type="text"/>	06.084.00
(min. 2.5 x stroke + 90 mm + measurement D of end fittings + measurements of additional options)		
8. Piston rod end fitting (M10x1 threaded ends):	<input type="text" value="GZ"/>	06.061.00
9. Cylinder end fitting (see drawing for symbol):	<input type="text"/>	06.061.00
10. Additional options:	<input type="checkbox"/> Valve (5)	06.010.00
	<input type="checkbox"/> Protective tube (6) (+ 5 mm)	06.011.00

Additional details: e.g. up to 50 times the locking force in the force direction

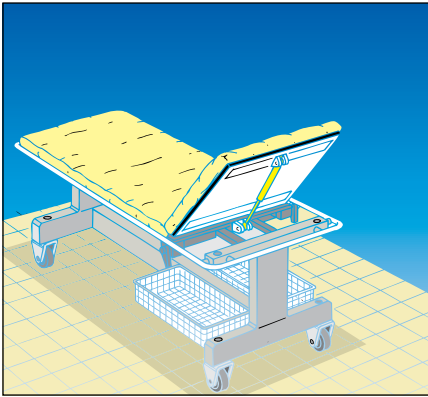

Release Devices For Locking Gas Springs

In locking gas springs the lock is released by pushing the release pin into the front of the piston rod so the piston rod can extend and retract. The pin is usually relatively hard to reach once installed so DICTATOR offers different release devices.

The release pin is 5 mm long. To release the locking the pin needs to be pushed in by 1 mm (in some cases 2 - 4 mm).

The force needed to activate the release pin depends on how much pressure is inside the gas spring and which release device is chosen.

Release Device with Bowden Wire

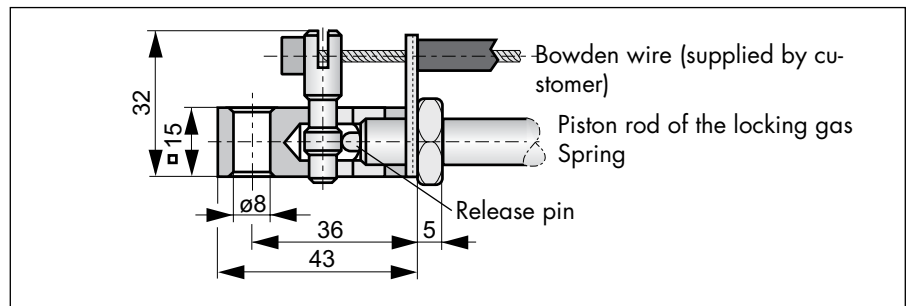

We recommend the release device with Bowden wire if it cannot be released close to the gas spring, only further away e.g. in aeroplane seats where it works on the side rest of the seat.

Release force: approx. 18 % of the rated force of the gas spring

Material

The release device with Bowden wire is made of the following materials:

Eyelet with release head	Aluminium AlCuMgPb
Lateral release fork	Free cutting steel 9 SMnPb36K
Guide plate	1 mm sheet steel

Installation

We recommend Bowden wires used on bicycles, \varnothing 2 mm, with plastic covering.

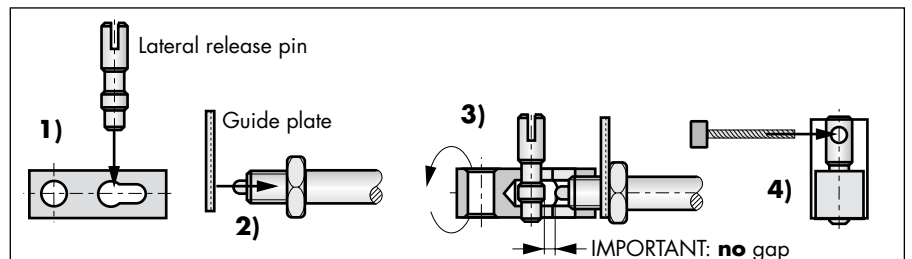

The release device for Bowden wire is screwed to the threaded end on the piston rod. The Bowden wire itself is not supplied as the required length of the rope is always different.

Mounting of the release device for Bowden wires:

- 1) Insert the lateral release fork into the hole of the eyelet until it appears on the surface.
- 2) Slide the guide plate over the piston rod towards the nut.
- 3) Screw the eyelet with release head onto the piston rod. Please make sure the release pin is completely released so that it is not moved at all. Also check that no gap remains either (see diagram 3).
- 4) Thread the rope through the hole in the release fork and pull it through completely. From the opposite side pull the plastic covering of the Bowden wire on the rope up to the guide plate.

Order Information

Releasing device for Bowden wire

part no. 205238

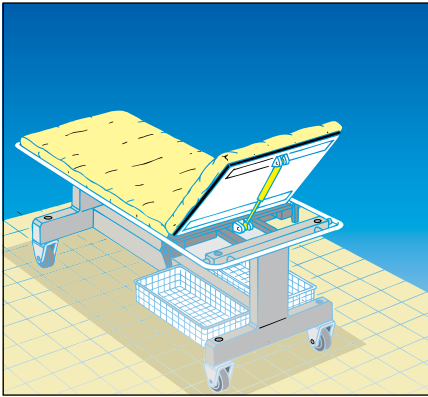

Release Devices For Locking Gas Springs, cont.

Besides the release device with Bowden wire DICTATOR offers the following possibilities to release the locking:

- You should opt for the release device with operating arm, if the device can be placed directly beside the gas spring, e.g. on lifting tables or operating tables.
- Hydraulic release device: It needs much less force for releasing the locking than the other two devices.

Release Device with Operating Arm

Eyelet with release head aluminium ALCuMgPb
 Operating arm C35K
 Head of arm plastics

Release force:
 approx. 18 % of the rated force of the gas spring

The release device is supplied completely with arm. In case you need a **different length of arm**, please contact us.

Hydraulic Release Device

Release force:
 approx. 4 % of the rated force of the gas spring
 Operating distance: approx. 17 mm

Attention: total length of the gas spring increases by 5 mm.

Eyelet with release head: aluminium
 Tube: polyamide PA, black

Release force:
 approx. 4 % of the rated force of the gas spring
 Operating distance: approx. 17 mm

Attention: total length of the gas spring increases by 5 mm.

Installation

The release devices are screwed completely to the threaded end on the piston rod. Please make sure the release pin is completely released when locked (that it is not moved at all), but that there is also no gap at all.

Order Information

Release device with operating arm	part no. 205239
Hydraulic release device, 150 mm tube	part no. 205248-150
Hydraulic release device, 230 mm tube	part no. 205248-230